

# Standard 2-Piece Ball Valve

## KHD-21E

Installation, Operation,  
& Maintenance Manual

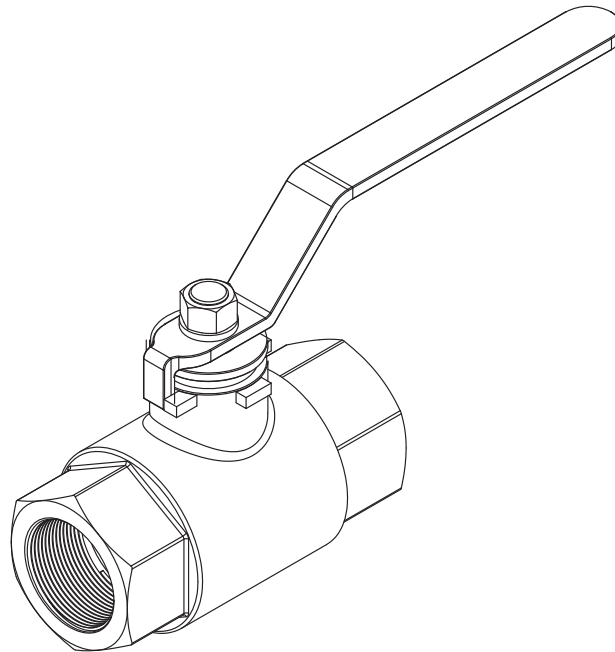

## Table of Contents

<b>I Introduction</b>	3
1.1 Contact Information	3
1.2 General Notes	3
1.3 Precautions and Warnings	3
1.4 Storage	4
<b>II Installation</b>	4
2.1 General Notes	4
2.2 Installation of Ends	5
<b>III Operation</b>	5
3.1 Handling	6
3.2 Cleaning	6
3.3 Manual Operation	6
3.4 Remote Operation	6
<b>IV Maintenance</b>	6
4.1 General Notes	6
4.2 Maintenance Frequency	6
4.3 Disassembly	7
4.4 Reassembly	7
4.5 Troubleshooting	7
4.6 Technical Data and Product Information	8

# Chapter I

## Introduction

The manual is provided to ensure proper installation, operation & maintenance for KHD-21E Standard 2-Piece Ball Valve, manufactured and supplied by KLINGER DIE ERSTE INDUSTRY CO., LTD. The valves are identified by marking on the body or on a name plate or both.

### 1.1 Contact Information

For information concerning warranties, or for questions pertaining to installation, operation or maintenance of KLINGER Die Erste products, contact:

KLINGER DIE ERSTE INDUSTRY CO., LTD.  
5F-1, No.936, Sec. 4, Wen-Xin Road,  
Taichung City, Taiwan 406

Phone: +886 4 22310059  
Fax: +886 4 22360236  
Email: sales@die-erste.com

To order replacement parts, contact KLINGER Die Erste sales at address listed above.

### 1.2 General Notes

The following instructions refer to KLINGER Die Erste KHD-21E Standard 2-Piece Ball Valve as described in the KLINGER Die Erste current catalog.

Keep the protective covers in place until the valve is ready for installation. Valve performance depends upon prevention of damage to ball surface. After removing the cover make sure that the valve is completely open and free of obstructions, dirt, particles or any materials that may cause seat or seal damage.

Valves may contain a silicon-based lubricant for transportation, which aids in the assembly of the valve. Lubricant may be removed with a solvent if found objectionable. Alternatively valves can be ordered free of lubricants upon request.

Certain ferrous valves contain phosphate material, and are oil dipped during the course of manufacture. However, the processes used are completely non-toxic.

### 1.3 Precautions and Warnings

Choose the correct material of valve for different applications before obtaining the valve. The user should be aware of the operating situation, fluid properties, and the possible outcomes when implementing valves into the pipeline system. KLINGER Die Erste suggests that the user should make estimation beforehand.

Fluid undergoes property changes with respect to outside factors, particularly fluid left inside the sealed cavity. When temperature and pressure exceed allowable value, valve failure may occur.

The KHD-21E Standard 2-Piece Ball Valve are generally not recommend for throttling services, due to both fluid flow and ball leading edge may damage or deform the resilient ball seats, and consequently causing leakage problem. Further, high fluid velocity or the presence of solid particles in suspension will further reduce seat life in throttling applications.

Do not attempt to remove the cap from the body during operation, especially with the presence of high pressure in the pipeline system.

For safety concern, unstable fluid should not be used in the pipeline system, unless otherwise spec-

#### CAUTION:

Before removing valve from pipeline, operator should be aware of that: media flowing through the valve may be corrosive, toxic, flammable, or of a contaminant nature. Where there is evidence of harmful fluids having flowed through the valve, the utmost care must be taken. It is suggested that the following safety precautions should be taken when handling valves.

- 1) Always wear eye shields.
- 2) Always wear gloves and footwear.
- 3) Wear protective headgear.
- 4) Ensure that running water is readily accessible.
- 5) Fire extinguisher must be obtainable if media is flammable.

Check the line gauge to ensure that no pressure is present at the valve. Ensuring media is released by operating valve slowly to the half open position. Ideally, the valve should be decontaminated when the ball is in the half open position.

ified with the category III in Declaration of conformity.

These valves, when installed, have body connectors which form an integral part of the pipeline and the valve cannot be removed from the pipeline without being dismantled.

### 1.4 Storage

If the valves are not to be installed immediately, please store the valve carefully before installation, preferably indoors in a dry and clean place. Also, the valve ports should be sealed by plastic caps to prevent dirt from entering and damaging inner parts.

## Chapter II

# Installation

Flush the pipeline carefully before installing the valve. The particles of dirt or debris or welding may damage the ball sealing surface and seats. Also, before installing, check all valve and pipe connection to ensure threads are free from defects.

**CAUTION:**  
Do not exceed the valve performance limitation.

**CAUTION:**  
Before installing, make sure the line pressure has been relieved, and any hazardous fluids have been drained or purged from the system.

### 2.1 General Notes

#### 1) Direction

KHD-21E Standard 2-Piece ball valves are bi-directionally sealed unless otherwise specified.

**Note:**  
If requested, valves with upstream hole in ball are one-way valves.

#### 2) Position

The body, cap and gasket are in the connection area of ball valve and pipeline. The bear weight ability and gradient are very important to the pipe installation. Do not make the pressure from the pipeline, and stress to concentrate on the connecting area of body and cap. Ball, seat, and stem will be damaged. Consequently, deformation and leakage may occur.

**Note:**  
Most of the valves do not restrict the flow direction when installing the KHD-21E Ball Valve. However, KLINGER Die Erste suggests vertical or horizontal position to maximize sealing and reduce the accumulation. In the case of vertical installation, upstream pressure should be located above, since in the floating ball design, the ball helps the sealing effects.

#### 3) Fittings

Select the correct size of fittings according to the pipeline specification. Mating the valve to the pipe-

line adequately with appropriate bolts. Do not attempt to correct pipeline misalignment by means of flanged bolting.

**Note:**

Over tightening of any side may cause leakage.

#### 4) Systems hydrostatic test

Before delivery, valves are tested 1.5 times the allowable pressure at ambient temperature in OPEN position. However, after installation, the piping system may subject to system tests, as condition not to exceed the marking pressure.

#### 5) Pre-Installation Wash

Before the valve installation, clean the pipeline system to remove any foreign deposits by water. Clean the connecting flanged end surfaces as well to ensure tight sealing.

### 2.2 Installation of Ends

#### Threaded Ends

It is not necessary to disassemble threaded end valves before installation. Note that the taper threaded fitting should not be over tightened.

## Chapter III

# Operation

For manual operation, shift the handle in clockwise direction for CLOSED and counter-clockwise for OPEN.

If the handle is in parallel position with the flow direction, the valve is OPEN. If the handle is in right angle position with the flow direction, the valve is CLOSED.

When installing actuator or the valve is operated with removable handle, the user should ensure the position of the valve whether open or close. The Double-D orientation indicates whether the valve is in OPEN or in CLOSED position. The below Figure 3.1 provides the visual understanding of above explanation.

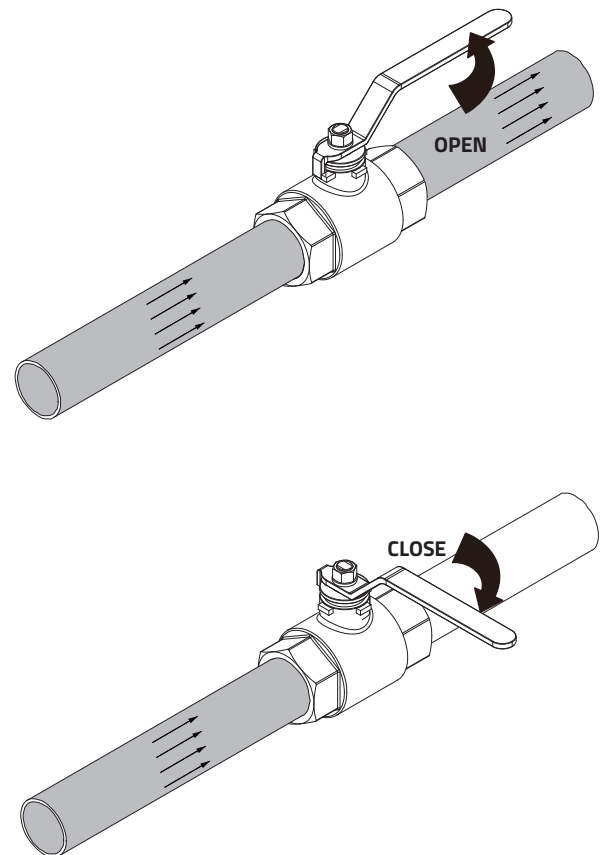

**Figure 3.1 Rotation Direction for CLOSED and OPEN position**

### 3.1 Handling

During the ball valve installation, it must follow the procedure to handle at the both side of the bodies. If using cable for big size valve, make sure the cable must be strong enough to ensure the safety during the installation.

Never lift the valve package by the actuator, positioner, limit switch or their piping. The Valve damage or personal injury may occur from falling parts.

### 3.2 Cleaning

Even though the valves were transported under a clean environment, operator must check if there is any foreign body or dusts inside the bore. If yes, clean the valve before installation. Operator may clean the valves by water, compression air, or steam. For cleaning operation, first step is put the valve bore perpendicular to the ground and clean, ensure all the dusts are removed from the bore. The second step is to check and clean all the connecting pipe bore and connection area. No flush, rust and foreign bodies are allowed to avoid the blocking and leakage.

### 3.3 Manual Operation

KLINGER Die Erste KHD-21E Standard 2-Piece Ball Valve have  $\frac{1}{4}$  turn operation opening in a counter-clockwise direction. When the handle is positioned across the pipeline, this indicates that the valve is closed. When the handle is positioned parallel with the pipeline, this indicates the valve is open.

### 3.4 Remote Operation

The KHD-21E ball valve is designed for manual use instead of pneumatic or electric actuation without notification. If requests, please consult your KLINGER Die Erste representative for more information.

#### CAUTION:

Keep hands, other parts of the body, tool and other objects out of the open flow port. Leave no foreign object inside the pipeline. When the valve is actuated, the ball segment act as a cutting device. Also, the segment position may change when the valve is moved. The failure may result in damage or personal injury.

## Chapter IV: Maintenance

#### CAUTION:

Do not dismantle the valve or remove it from the pipeline while the valve is pressurized.

### 4.1 General Notes

With Self-wipe ball and seats, KLINGER Die Erste valves have a long, trouble-free life, and maintenance is seldom required. However, when necessary, valves may be refurbished, using a minimal number of components, none of which require machining. The valves are designed for easy service and assembly in the field.

Before maintenance, user should check availability of the service kits for KHD-21E Standard 2-Piece Ball Valve. We strongly recommend using the genuine service kit produced directly from the manufacture facility. For more information, please contact your KLINGER Die Erste representatives. Service kits may be available locally; however, KLINGER Die Erste is not responsible for any of the valve damage caused by using non-genuine spare parts.

### 4.2 Maintenance Frequency

The maintenance frequency is determined based upon the application of the valve. User should consider the following factors when determining the maintenance time interval: fluid type, flow velocity, operation frequency, pressure and temperature.

#### Note:

For the KHD-21E Standard 2-Piece Ball Valve, KLINGER Die Erste recommends inspecting the valve at least every (1) year.

#### Note:

Please use the original spare parts to ensure the valve functions well.

#### Note:

When sending back the valve to KLINGER Die Erste for investigation, do not disassemble it. Clean the valve carefully and flush the valve internals. If possible, inform us about the medium used in the valve.

### 4.3 Disassembly

**⚠ CAUTION:**

Pipeline and valve must be depressurized by shutting off the valve and bleed line, cycle the valve once and leave it half open to relieve the pressure from the body cavity.

1. Depressurized and empty the seal up fluid before disassembly. Be cautious of the fluid inside the valve as they can be poisonous and flammable.
2. Valve should be positioned vertically by resting body side on clean ground surface, preferably covered with rubber sheet.
3. Shift the HANDLE (13) so the valve is in the close position; otherwise, the valve BALL (3) cannot be removed from the bore later.
4. Remove the HANDLE NUT(11), HANDLE WASHER (10) and the HANDLE (13).
5. Remove the side CAP (2) .
6. Remove the GASKET (6) and SEAT (4).
7. Remove the BALL (3) and the other SEAT (4) from the BODY (1).
8. Remove the STEM (5) by removing GLAND (9) as applicable.
9. Push the STEM (3) into the bore and remove it.
10. Remove all stem PACKINGS (8).
11. Remove the THRUST WASHER (7) from the STEM (5)
12. All the components should be stored in a clean place.

**Note:**

Damaged internals to be replaced by KLINGER Die Erste repair kits only.

### 4.4 Reassembly

Before reassembly, inspect the valve for any damage on body adaptor and all internals. Note that after the welding has been broken, it cannot be putting back function.

1. Follow the same step as point 2 mentioned in Section 4.3.
2. Insert the body SEAT (4) in position.
3. Insert the THRUST WASHER (7) on the STEM (5),

and lastly install the STEM (5) from inside the BODY (1).

4. Insert the stem PACKINGS (8) and ensure proper locking of stem with GLAND (9).
5. Align STEM (5) parallel with the body bore.
6. Gently slide the BALL (3) over the STEM (5) and rotate the BALL (3) so that they are interlocked.
7. Place GASKET (6) and SEAT (4) on the CAP (2).
8. Assemble the valve by putting end CAP (2) on the BODY (1), tighten the CAP (2). Perform welding between the end cap and the valve body if necessary.
9. Place the HANDLE (13), HANDLE WASHER (10) and HANDLE NUT (11) on the STEM (5). Tighten the HANDLE NUT (11) with HANDLE WASHER (10) to secure the HANDLE (13).
10. Ensure smooth operation of valve during opening and closing.

### 4.5 Troubleshooting

The following table lists the possible malfunctions.

**Table 4.1 Troubleshooting Table**

Symptom	Possible fault	Actions
Leakage through a closed Valve (Internal Leakage)	Damaged ball surface	Replace the ball
	Damaged seats	Replace seats
	Ball might not be fully closed	Realign the ball
Irregular ball movement	Fluid accumulated on the surface.	Flush the ball from inside
	Ball or seat damaged	Clean or replace the ball or seat
Valve leaking from stem (External Leakage)	Stem nut are loosened	Tighten the stem nut
	Parts are worn or damaged	Replace the necessary parts
Valve leaking from body and cap joint (External Leakage)	Damaged or breakage of gasket	Replace gaskets
	Relaxation of studs due to gasket creep	Re-tighten the studs evenly
Valve too hard to operate	Damaged seats	Replace seats
	High pressure	Confirm the pressure rating
	Foreign particles in valve	Clean the internals

**4.6 Technical Data and Product Information**

**KHD-21E-1000 psi**

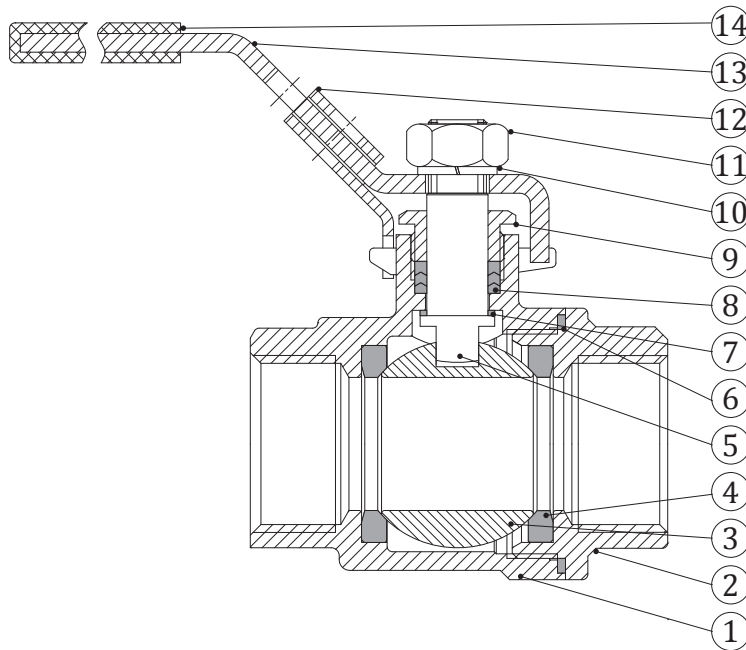

NO	PART NAME	MATERIAL
1	BODY	CF8M
2	CAP	CF8M
3	BALL	CF8M
4	SEAT	PTFE
5	STEM	SS 316
6	GASKET	PTFE
7	THRUST WASHER	PTFE

NO	PART NAME	MATERIAL
8	PACKING	PTFE
9	GLAND	SS 304
10	HANDLE WASHER	SS 304
11	HANDLE NUT	SS 304
12	LOCKING DEVICE	SS 304
13	HANDLE	SS 304
14	PLASTIC COVER	VINYL